

ロングエルボ SUS304

■単位：mm

| サイズ 外径 × 肉厚 | A | 研磨 | サイズ 外径 × 肉厚 | A | 研磨 |
|----------------|------|--------|----------------|-------|--------|
| 19 × 2.0 | 38.1 | ● HL 6 | 50 × 2.0 | 57.2 | ● HL 6 |
| 21.7 × 2.0 | 38.1 | ● HL 6 | 60.5 × 2.0 | 76.2 | ● HL 6 |
| 25 × 2.0 | 33.0 | ● HL 6 | 76.3 × 2.0 | 95.3 | ● HL 6 |
| 27.2 × 2.0 | 38.1 | ● HL 6 | 89.1 × 2.0 | 114.3 | ● HL 6 |
| 32 × 2.0 | 38.1 | ● HL 6 | 101.6 × 2.0 | 133.4 | ● HL 6 |
| 34 × 2.0 | 38.1 | ● HL 6 | 114.3 × 2.0 | 152.4 | ● HL 6 |
| 38 × 2.0 | 47.2 | ● HL 6 | 139.8 × 3.0 | 190.5 | ● HL 6 |
| 42.7 × 2.0 | 47.6 | ● HL 6 | 165.2 × 3.0 | 228.6 | ● HL 6 |
| 48.6 × 2.0 | 57.2 | ● HL 6 | | | |

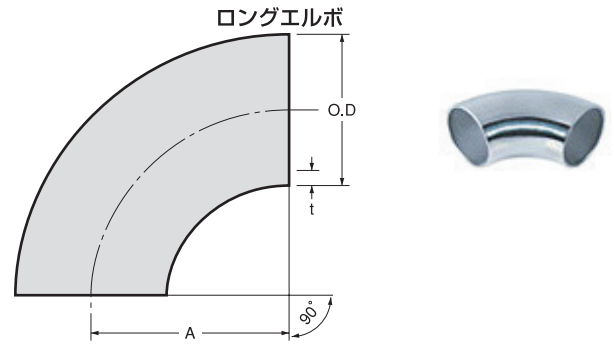

ネック付エルボ SUS304

■単位：mm

| サイズ O.D | T | R | S | A | H | P _{MAX} | Q _{MAX} | 研磨 |
|------------|-----|-------|------|-----|-------|------------------|------------------|--------|
| 19.0 | 2.0 | 28.6 | 21.4 | 50 | 59.5 | 0.5 | 0.5 | ● HL 6 |
| 21.7 | 2.0 | 28.6 | 21.4 | 50 | 60.9 | 0.5 | 0.5 | ● HL 6 |
| 25.0 | 2.0 | 28.6 | 21.4 | 50 | 62.5 | 0.5 | 0.5 | ● HL 6 |
| 27.2 | 2.0 | 28.6 | 21.4 | 50 | 63.6 | 0.5 | 0.5 | ● HL 6 |
| 32.0 | 2.0 | 28.6 | 21.4 | 50 | 66.0 | 0.5 | 0.5 | ● HL 6 |
| 34.0 | 2.0 | 38.1 | 21.9 | 60 | 77.0 | 0.5 | 0.5 | ● HL 6 |
| 38.0 | 2.0 | 38.1 | 21.9 | 60 | 79.0 | 0.5 | 0.5 | ● HL 6 |
| 42.7 | 2.0 | 31.8 | 28.2 | 60 | 81.4 | 0.5 | 0.5 | ● HL 6 |
| 48.6 | 2.0 | 38.1 | 21.9 | 60 | 84.3 | 0.5 | 0.5 | ● HL 6 |
| 50.0 | 2.0 | 38.1 | 21.9 | 60 | 85.0 | 0.5 | 0.5 | ● HL 6 |
| 60.5 | 2.0 | 50.8 | 29.2 | 80 | 110.3 | 0.5 | 0.5 | ● HL 6 |
| 76.3 | 2.0 | 63.5 | 16.5 | 80 | 118.2 | 0.5 | 0.5 | ● HL 6 |
| 89.1 | 2.0 | 76.2 | 13.8 | 90 | 134.6 | 0.5 | 0.5 | ● HL 6 |
| 101.6 | 2.0 | 88.9 | 21.1 | 110 | 160.8 | 1.0 | 0.5 | ● HL 6 |
| 114.3 | 2.0 | 101.6 | 18.4 | 120 | 177.2 | 1.0 | 0.5 | ● HL 6 |

ネック付エルボ

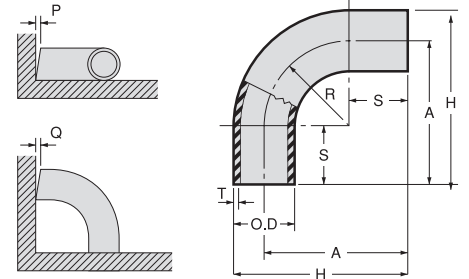

シャープエルボ SUS304

■単位：mm

| サイズ O.D | T | R1 | R2 | S1 | S2 | A | H1 | H2 | P | Q | 研磨 |
|------------|-----|------|------|----|------|------|------|------|-----|-----|--------|
| 27.2 | 2.0 | 26.0 | 5.0 | 74 | 67.8 | 86.4 | 72.8 | 100 | 0.5 | 0.5 | ● HL 6 |
| 32.0 | 2.0 | 28.0 | 7.0 | 62 | 51.0 | 74.0 | 58.0 | 90.0 | 0.5 | 0.5 | ● HL 6 |
| 34.0 | 2.0 | 28.0 | 7.0 | 57 | 44.0 | 68.0 | 51.0 | 85.0 | 0.5 | 0.5 | ● HL 6 |
| 38.0 | 2.0 | 32.0 | 8.0 | 53 | 39.0 | 66.0 | 47.0 | 85.0 | 0.5 | 0.5 | ● HL 6 |
| 42.7 | 2.0 | 35.0 | 10.0 | 45 | 27.3 | 58.7 | 37.3 | 80.0 | 0.5 | 0.5 | ● HL 6 |

シャープエルボ

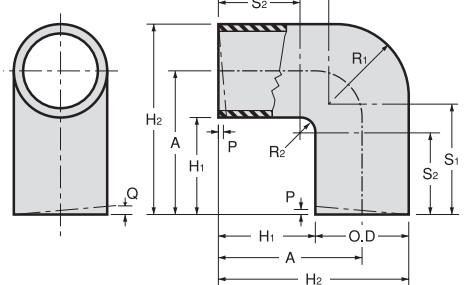

パイプコーナーエルボ SUS304

■単位：mm

| サイズ 外径 × 肉厚 × R | A × B | 研磨 |
|--------------------|-----------|------|
| 27.2 × 1.5 × 35 | 150 × 150 | ● HL |
| 32 × 1.5 × 40 | 150 × 150 | ● HL |
| 34 × 1.5 × 40 | 150 × 150 | ● HL |
| 38 × 1.5 × 50 | 150 × 150 | ● HL |
| 42.7 × 1.5 × 55 | 150 × 150 | ● HL |
| 48.6 × 1.5 × 60 | 150 × 150 | ● HL |

上記以外のサイズも製作可能です。

パイプコーナーエルボ

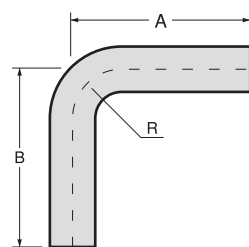

いままでのコーナー部分の曲げがさらに小さくなってストレート部分を長くしたパイプコーナーエルボ。

球 SUS304 ※メーカー取寄

■単位：mm

| サイズ 外径 厚み | 研磨 | サイズ 外径 厚み | 研磨 | サイズ 外径 厚み | 研磨 | サイズ 外径 厚み | 研磨 |
|--------------|----|--------------|----|--------------|----|--------------|----|
| 26.0 1.0 | 8 | 60.0 1.0 | 8 | 115.0 1.5 | 8 | 200.0 1.5 | 8 |
| 30.0 0.8 | 8 | 70.0 1.0 | 8 | 120.0 1.5 | 8 | 240.0 1.5 | 8 |
| 34.0 1.5 | 8 | 70.0 1.5 | 8 | 125.0 1.5 | 8 | 300.0 1.5 | 8 |
| 38.0 1.5 | 8 | 76.0 0.8 | 8 | 130.0 1.5 | 8 | 400.0 1.5 | 8 |
| 40.0 0.8 | 8 | 80.0 1.0 | 8 | 140.0 1.5 | 8 | | |
| 50.0 0.8 | 8 | 90.0 1.0 | 8 | 150.0 1.5 | 8 | | |
| 50.8 1.2 | 8 | 100.0 1.5 | 8 | 180.0 1.5 | 8 | | |

球

