

パンチングメタル・エキスパンドメタル

SUS304 BA(板厚0.3mm~2.0mm)・2B(板厚3.0mm) ※一部サイズ2B材・片研#400もごさいます。お問い合わせください。
アルミ(t=1.2mm以下 A1050、その他 A1100) ●印はSUS304、◎印はアルミ

サイズ	φ(孔径) × P(ピッチ)	開口率(%)	板厚											
			0.3	0.4	0.5	0.6	0.8	1.0	1.2	1.5	2.0	3.0		
1m×2m	○ × +	32.0	●	●	●◎	●	●◎	●◎	●	●◎				
	0.5 × 1.09	19.0	●	●										
	0.8 × 1.55	24.2				●								
	1 × 2	22.6			●	●	●	●						
	1.5 × 3	22.6			●		●	●		●				
	2 × 3	40.2						●		●				
	2 × 3.5	29.6				●	●	●◎	●	●				
	2.5 × 4	35.4						●						
	3 × 4	50.9			●		●	●◎						
	3 × 5	32.6		●	●◎	●	●◎	●◎	●◎	●◎	●◎	●◎	●	
	4 × 5	57.9						●						
	4 × 6	40.2						●						
	4 × 7	29.6				●	●	●◎	●	●	●◎			
	5 × 6	62.9						●						
	5 × 7	46.2						●						
	5 × 8	35.4			●	●	●◎	●◎	●◎	●◎	●◎	●◎	●	
	6 × 8	50.9					●	●		●				
	6 × 9	40.2				●	●	●◎	●	●	●	●◎		
	8 × 10	57.9				●	●	●◎	●	●		●		
	8 × 12	40.2						●	●	●◎	●◎	●◎	●	
	10 × 15	40.2						●	●◎	●	●◎	●◎	●◎	●◎
12 × 18	40.2								●	●◎	●◎	●◎		
15 × 20	50.9								●	●◎	●◎	●◎		
20 × 30	40.2								●	●◎	●◎	●◎		
3角 × 5並列	36.0							●						
8角 × 10並列	64.0							●						
長孔3 × 20	39.7						●							
4'×8' (1219×2438)	3 × 5	32.6					●	●	●	●				
	5 × 8	35.4					●	●	●	●	●	●	●	
	6 × 9	40.2						●	●	●	●	●	●	
	10 × 15	40.2					●	●	●	●	●	●	●	
	HL10 × 15SPV	40.2							●					
アルミ 4'×8' (1250×2500)	5 × 8										◎	◎		
	8 × 12										◎	◎		
	10 × 15										◎	◎		

SUS430 2B

1m×2m	3 × 5	32.6					●	●					
	5 × 8	35.4					●	●					

上記以外、特注品の製造から切断加工も致します。

●孔径、ピッチについて

※60°千鳥抜き(通常丸孔はこの形状です)

(例) No.58 10φ×15P

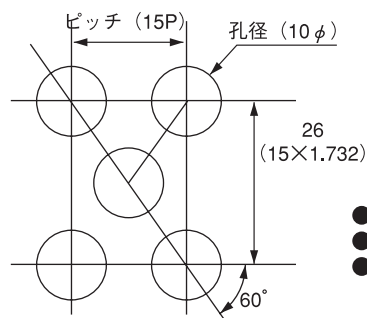

- 孔 径: 孔の直径
- ピ ッ チ: 孔の中心から中心迄の長さ
- 60° 千鳥 3つの孔が常に60°の正三角の位置関係

●目方向について

2000(長手方向、L)

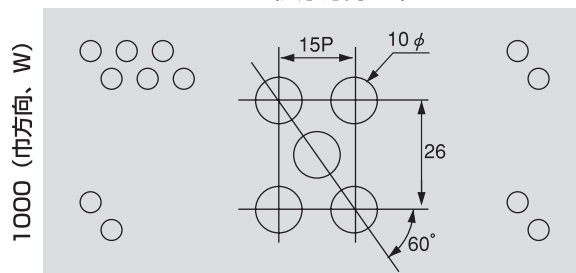

エキスパンドメタル SUS304

品番	メッシュ		T (板厚)	W (刻み巾)	1×2	4×8	素材
	SW (短目) × LW (長目)						
XS-31	12 × 30.5	30.5	1.2	1.5	●		2B
XS-32	12 × 30.5	30.5	1.5	1.8	●		2B
XS-33	12 × 30.5	30.5	2.0	2.0	●		2B
XS-42	22 × 50.8	50.8	2.0	2.0	●		No.1
XS-43	22 × 50.8	50.8	3.0	3.0	●	●	No.1
XS-62	34 × 76.2	76.2	3.0	3.0	●		No.1
XS-63	34 × 76.2	76.2	4.0	4.0	●	●	No.1
XG-21	36 × 101.6	101.6	4.5	5.0	●	●	No.1
XG-22	36 × 101.6	101.6	6.0	6.0	●	●	No.1

※上記以外のサイズ、特注品の製造から切断加工・フラット加工も承ります。
 ※在庫状況につきましては、お問い合わせください。

■エキスパンドメタル各部の名称

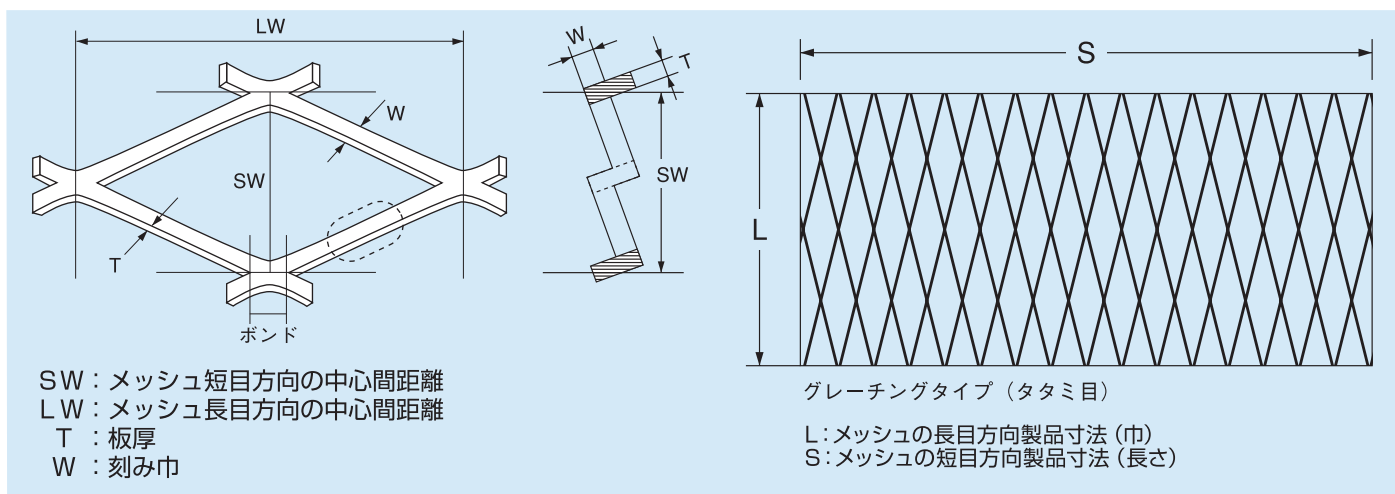

■パンチングメタル各部の名称

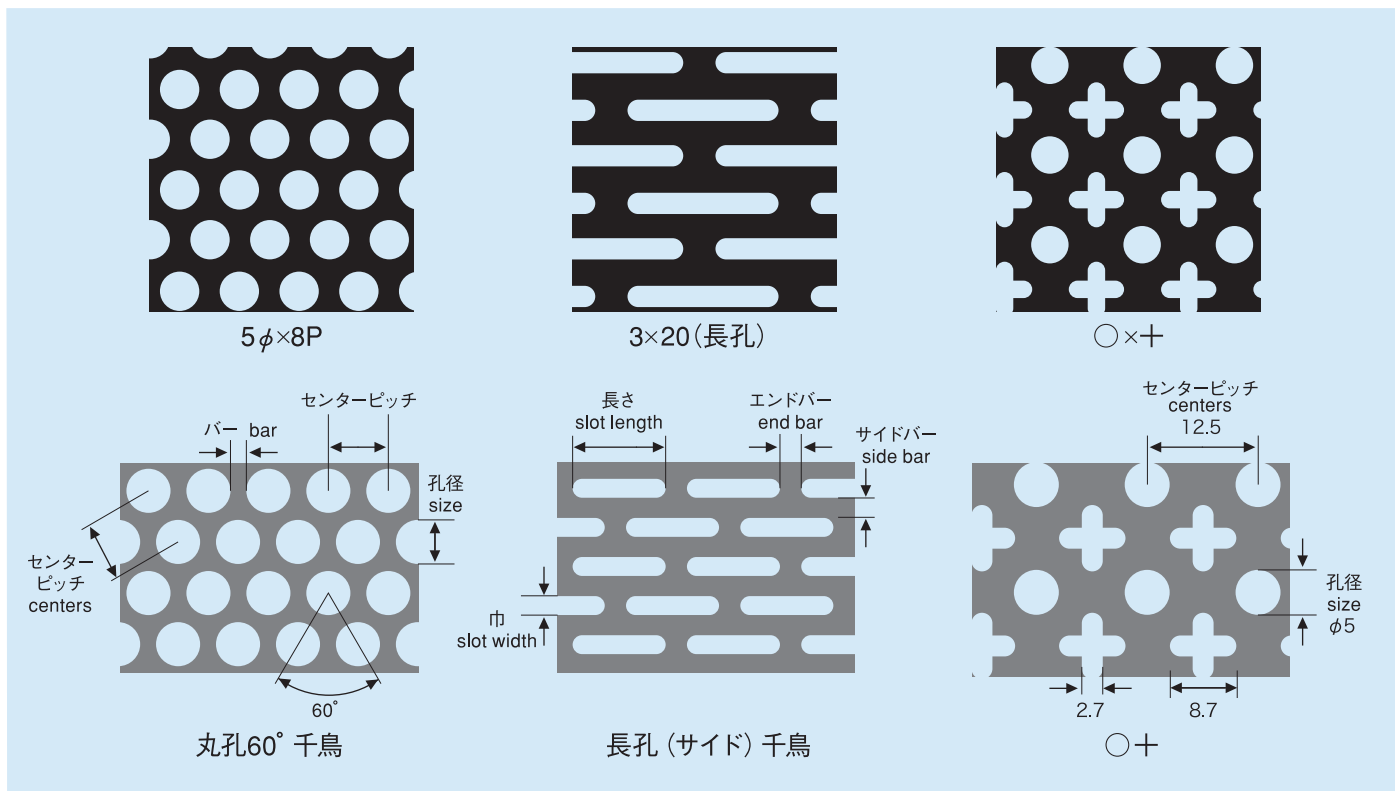

※サイズは左記の表をご覧ください。

製品寸法の許容差

予め特約されたものを除き、次の通りといたします。

L許容差	+25mm - 0mm	S許容差	+25mm - 0mm
------	----------------	------	----------------

■エキスパンドメタルの重量計算法

$$\text{単位重量} = \frac{\text{鋼板の単位重量}}{\text{引伸率}}$$

$$\text{鋼板の単位重量 (kg/m}^3\text{)} = 7.93 \times T \text{ (kg/m}^3\text{)}$$

$$\text{引伸率} = \frac{SW}{2W}$$