

ロングエルボ SUS304

■単位：mm

サイズ O.D	T	A	研磨	サイズ O.D	T	A	研磨
19.0	2.0	38.1	● HL 6	50.0	2.0	57.2	● HL 6
21.7	2.0	38.1	● HL 6	60.5	2.0	76.2	● HL 6
25.0	2.0	33.0	● HL 6	76.3	2.0	95.3	● HL 6
27.2	2.0	38.1	● HL 6	89.1	2.0	114.3	● HL 6
32.0	2.0	38.1	● HL 6	101.6	2.0	133.4	● HL 6
34.0	2.0	38.1	● HL 6	114.3	2.0	152.4	● HL 6
38.0	2.0	47.2	● HL 6	139.8	3.0	190.5	● HL 6
42.7	2.0	47.6	● HL 6	165.2	3.0	228.6	● HL 6
48.6	2.0	57.2	● HL 6				

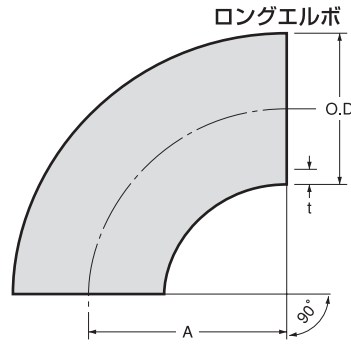

ネック付エルボ SUS304

■単位：mm

サイズ O.D	T	R	S	A	H	P _{MAX}	Q _{MAX}	研磨
19.0	2.0	28.6	21.4	50	59.5	0.5	0.5	● HL 6
21.7	2.0	28.6	21.4	50	60.9	0.5	0.5	● HL 6
25.0	2.0	28.6	21.4	50	62.5	0.5	0.5	● HL 6
27.2	2.0	28.6	21.4	50	63.6	0.5	0.5	● HL 6
32.0	2.0	28.6	21.4	50	66.0	0.5	0.5	● HL 6
34.0	2.0	38.1	21.9	60	77.0	0.5	0.5	● HL 6
38.0	2.0	38.1	21.9	60	79.0	0.5	0.5	● HL 6
42.7	2.0	31.8	28.2	60	81.4	0.5	0.5	● HL 6
48.6	2.0	38.1	21.9	60	84.3	0.5	0.5	● HL 6
50.0	2.0	38.1	21.9	60	85.0	0.5	0.5	● HL 6
60.5	2.0	50.8	29.2	80	110.3	0.5	0.5	● HL 6
76.3	2.0	63.5	16.5	80	118.2	0.5	0.5	● HL 6
89.1	2.0	76.2	13.8	90	134.6	0.5	0.5	● HL 6
101.6	2.0	88.9	21.1	110	160.8	1.0	0.5	● HL 6
114.3	2.0	101.6	18.4	120	177.2	1.0	0.5	● HL 6

ネック付エルボ

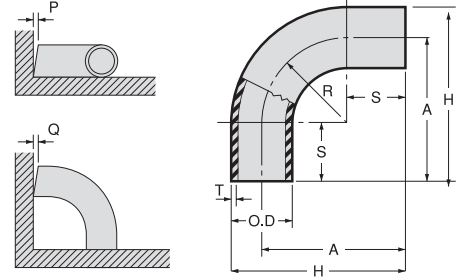

シャープエルボ SUS304

■単位：mm

サイズ O.D	T	R ₁	R ₂	S ₁	S ₂	A	H ₁	H ₂	P	Q	研磨
27.2	2.0	26.0	5.0	74	67.8	86.4	72.8	100.0	0.5	0.5	● HL 6
32.0	2.0	28.0	7.0	62	51.0	74.0	58.0	90.0	0.5	0.5	● HL 6
34.0	2.0	28.0	7.0	57	44.0	68.0	51.0	85.0	0.5	0.5	● HL 6
38.0	2.0	32.0	8.0	53	39.0	66.0	47.0	85.0	0.5	0.5	● HL 6
42.7	2.0	35.0	10.0	45	27.3	58.7	37.3	80.0	0.5	0.5	● HL 6

シャープエルボ

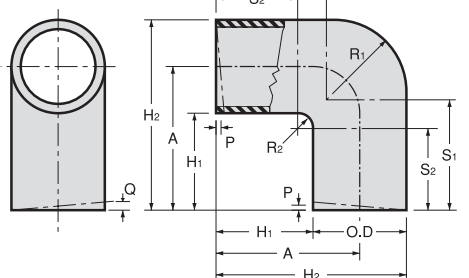

パイプコーナーエルボ SUS304

■単位：mm

サイズ O.D	T	R	A×B	研磨
27.2	1.5	35	150×150	● HL
32.0	1.5	40	150×150	● HL
34.0	1.5	40	150×150	● HL
38.0	1.5	50	150×150	● HL
42.7	1.5	55	150×150	● HL
48.6	1.5	60	150×150	● HL

上記以外のサイズも製作可能です。

パイプコーナーエルボ

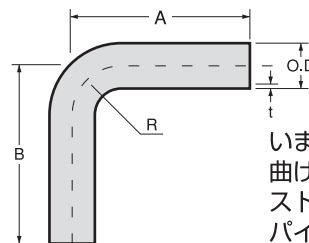

いままでのコーナー部分の曲げがさらに小さくなってストレート部分を長くしたパイプコーナーエルボ。

球 SUS304 ※メーカー取寄

■単位：mm

サイズ O.D	T	研磨	サイズ O.D	T	研磨	サイズ O.D	T	研磨	サイズ O.D	T	研磨
26.0	1.0	8	60.0	1.0	8	115.0	1.5	8	200.0	1.5	8
30.0	0.8	8	70.0	1.0	8	120.0	1.5	8	240.0	1.5	8
34.0	1.5	8	70.0	1.5	8	125.0	1.5	8	300.0	1.5	8
38.0	1.5	8	76.0	0.8	8	130.0	1.5	8	400.0	1.5	8
40.0	0.8	8	80.0	1.0	8	140.0	1.5	8			
50.0	0.8	8	90.0	1.0	8	150.0	1.5	8			
50.8	1.2	8	100.0	1.5	8	180.0	1.5	8			

球

